

<https://doi.org/10.7577/formakademisk.5424>

Flemming Tvede Hansen
Associate Professor, PhD
The Royal Danish Academy
fth@kglakademi.dk

Isak Worre Foged
Professor, PhD
The Royal Danish Academy
hfog@kglakademi.dk

Vasiliki Fragkia
Research Assistant
The Royal Danish Academy
vfra@kglakademi.dk

A Multidisciplinary Approach to the Development of Thermal Clay Modules

ABSTRACT

This study focuses on the idea that industrial production methods, combined with a craft-based approach, enable the production of distinctive expressive thermal functionalities. We developed extruded modules based on a hands-on explorative craft approach in parallel with virtual simulations to explore how heat and cold are transported dynamically through building modules. This paper discusses the developed method and process used in a multidisciplinary approach that combines the quality of craft-based practice with architecture, engineering and programming, focusing on how craft practitioners experiment with material, technique and aesthetics in such a multidisciplinary approach. In this study, immediate concrete design proposals demonstrated a helpful way of establishing common ground for multidisciplinary collaboration. Concrete design proposals are pivotal in addressing the suggested design's advantages and disadvantages and clarifying the differences and potentials between the specialisations in question. Based on the initial design proposals, it was clear how the craftsman's previous experiences within crafts practice quickly led to the identification of realisable solutions based on experimental setups and aesthetic solutions and, at the same time, was able to foresee possible complications.

Keywords:

Ceramics, Extrusion, Crafting, Multidisciplinary collaboration, Virtual design simulation.

INTRODUCTION

This study investigates a method and process for developing thermal clay building modules that influence cooling and heating properties. The experimental study is based on a ceramic craft-based approach combined with parametric design-simulation methods using thermal flux and computer fluid dynamic simulation procedures. This study investigates how local clay can be shaped into expressive and functional thermal building modules based on a multidisciplinary approach that combines advanced design methods and low-practice manufacturing processes.

The project is based on a collaboration between a ceramic artist, an architect with training as an engineer and a programmer. This paper discusses the developed method and process used in a multidisciplinary approach that combines the quality of craft-based practice with the skills found in architecture, engineering and programming.

Because global temperatures are expected to rise dramatically over the next century (IPCC, 2021), buildings developed and built now must examine and adopt innovative thermal strategies, since methods that rely on fossil fuels are currently causing climate problems. Despite ancient thermal designs (Moe, 2013), the prevalence of heat, ventilation and air-conditioning systems prevail today through increased technological advancement and integration (Hawkes, 2019). However, it is critical to recognise the passive cooling techniques used in historic constructions (Joshi, 2018). Clay soil's local nature, combined with its inherent ability to improve conditions in buildings, directly addresses the challenge of limited materials and energy. Using a natural, local and accessible material coupled with its developed properties for thermal design, we aimed to explore a concrete example of how traditional materials can be part of a sustainable society in the future.

This study focuses on the idea that industrial production methods, combined with a craft-based approach, enable the production of distinctive expressive thermal functionalities. The combination of a craft-based approach to ceramics with advanced experimental digital production methods is widely carried out. An example is the project *Diversity*, which resulted from the collaboration between the Danish brick factory Strøjer Tegl and the robotic manufacturing company Odico. The project combined clay and a pre-programmed robotic wire cutter. The clay was cut with a metal wire while being extruded, and through the wire's movement, the curve and texture of the bricks were crafted following the design. In this way, the project took advantage of clay as a soft material using a traditional production technique while advancing a new technology (Bundgaard, 2021). In contrast, this study aimed to develop extruded modules based on a traditional hands-on explorative craft approach in parallel with virtual simulations of a single module to explore how heat and cold are transported dynamically through the modules. The craft approach enables an explorative and experimental approach that is distinctive, since the craftsperson directly interacts with the material and techniques in question in a way that utilises and emphasises the material quality of ceramics.

The greatest contribution of the study is the development of thermal building modules, as we intended to explore and discuss the potential of a multidisciplinary approach. Therefore, we attempted to answer the following research question: How can craft practitioners highlight the importance of experimenting with material, technique and aesthetics in the development of functional thermal building modules?

A CERAMIC CRAFT-BASED APPROACH

In this study, traditional ceramic craft practice focused on the relationship between the craftsperson and the material, where the craftsperson directly engaged with the material as a partner in the design process (Brinck & Reddy, 2020). Thus, in crafting, the craftsperson was guided by their interactions with the responsive material (Dormer, 1994, p. 56 ; Sennett, 2008, p. 125) and crafted and executed work in an intuitive and humanistic way (Leach, 1976, p. 2). Craft practice is thus defined as a creative process based on experiential knowledge in which the craftsperson works intuitively to allow for spontaneous acts and improvisation (Johns et al., 2014). Thus, we created examples of what could be done and how, offering general suggestions about a change to design practice (Binder & Redström, 2006).

In the study, we chose the technique of extrusion with red clay since it builds on the techniques used in the local industry (e.g. in the production of bricks at brick factories). We were interested in exploring the techniques and clay used locally to reduce transportation energy and to increase the relationship between a building's articulation and the locality of materials and fabrication processes into a designed form.

Briefly, the extrusion technique involves pressing clay through a template (see Figure 1). Extrusion is an effective tool for producing modules, such as bricks. However, the technique is limited, since the extruded shape can only reflect the template and will not allow for the production of double-curved surfaces. Nevertheless, this technique has productive potential when combined with a craft-based approach, which we demonstrate.



FIGURE 1. Extrusion technique, where clay is pressed through a template.

COMPUTATION-BASED STUDIES

In parallel to craft- and material-based investigations, computation-based studies of thermal simulations were conducted. The aim was to understand and advance the investigation method and the understanding of the thermal performance of clay building modules. The computational studies used the Rhinoceros–Grasshopper–Ladybug infrastructure, with the simulation engines Therm (thermal flux simulation for thermal transfer analysis), Radiance (solar irradiance simulation for surface temperature analysis) and OpenFoam (computer fluid dynamics simulation for airflow analysis).

Through the simulation, we investigated the similarities between the physical and virtual modules concerning airflow and thermal aspects to explore the material's potential, given the scale of a building.

COMMON GROUND

While the overall concept and the techniques were clear to all partners involved in the project, the process of developing the thermal clay building modules could have been clearer. The thermal aspects that influence cooling and heating properties in a building module were unknown to the craftsperson, and the material's behaviour in relation to the craft technique of extrusion was unknown to the architect and programmer. Nevertheless, our collective idea was to explore the potential in the relationship between hollow and massive parts in a building module, since air has an isolating function.

Initially, the architect and programmer suggested investigating possible thermal differences between angled, straight and curved hollow areas in a cubic module (see Figure 2). The suggested designs quickly resulted in a discussion about the aesthetics of the interplay between the hollow part and the outline of the module. In addition, we discussed ornamental potential when the modules were repeated as wall constructions, including an interlocking system that supports stackability. Finally, we

discussed a possible variation in the depth of the hollow part of the module that could strengthen airflow and thus thermal aspects.

Based on the initial discussion, we developed a new modular design that included the aspects we discussed. The inside and outside designs for the module were curved in similar ways and designed for a stackable interlocking module system (see Figures 3 and 4). Furthermore, three versions of the curvy module with different wall thicknesses were developed, making it possible to vary the perforated wall in terms of the depth of the surface and thus explore thermal aspects (see Figure 5).

The discussion in these initial steps clarified and reflected on the differences between the specialisations within the multidisciplinary collaborative team. These steps created essential common ground for collaboration. In these initial steps, it was clear how the craftspeople's previous experiences with the material and techniques yielded foresight into the potentials and complications related to the material's behaviour and ornamentation. At the same time, aspects of stackability and thermal potentials were featured in the joint discussion, thinking and design. Thus, the initial steps resulted in common ground based on concrete examples, which resulted in a concept that included considerations and an understanding of the principles of thermal aspects and aesthetics.

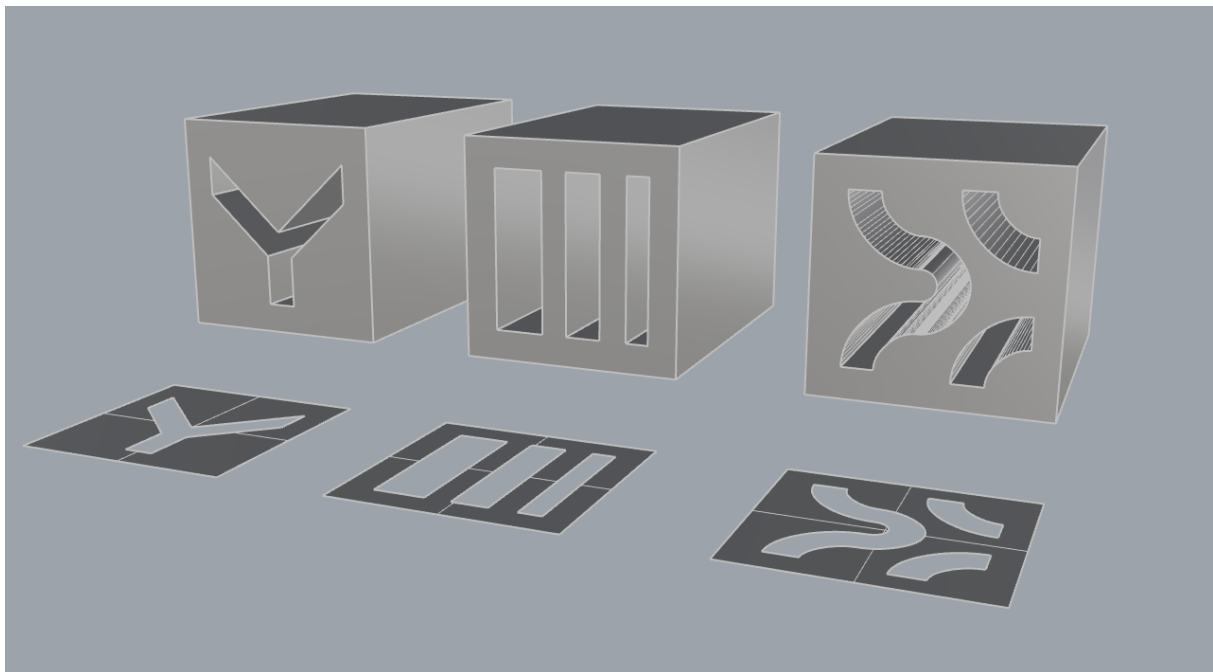

FIGURE 2. Initial design suggestions with the aim of investigating possible thermal differences between angled, straight and curved hollow areas in cubic modules.

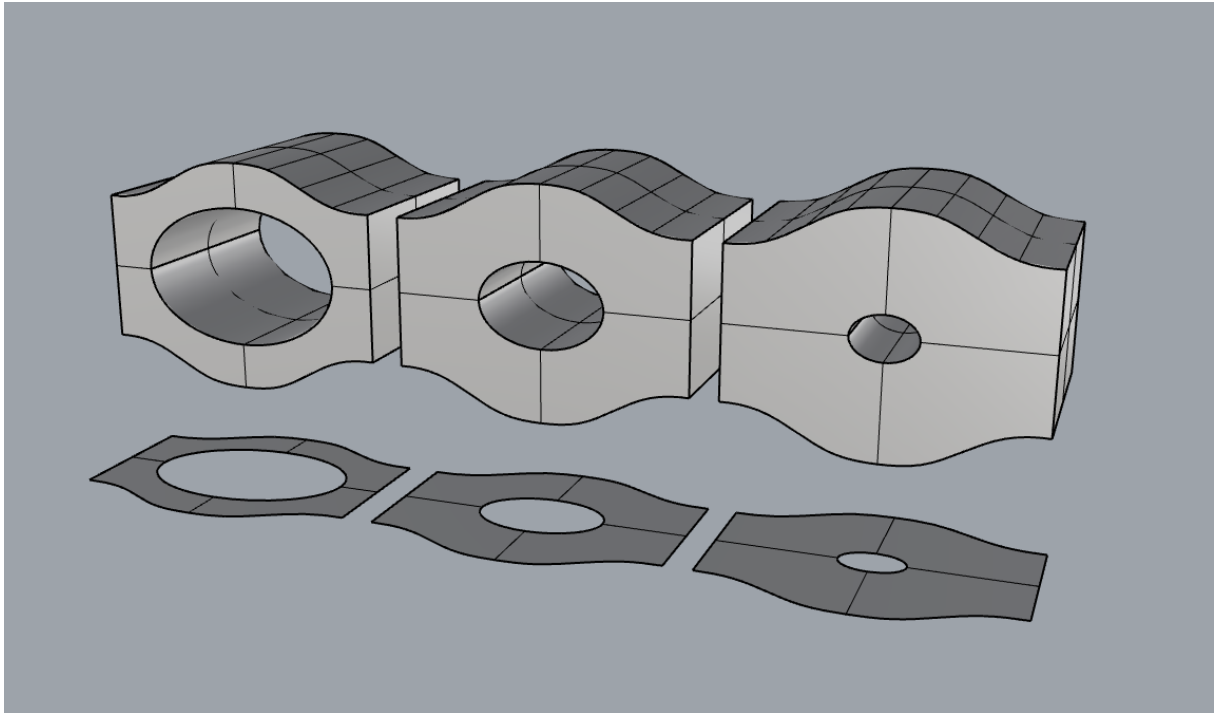

FIGURE 3. Three versions of curvy modules with different wall thicknesses were developed. The inside of each module reflects its outer shape.

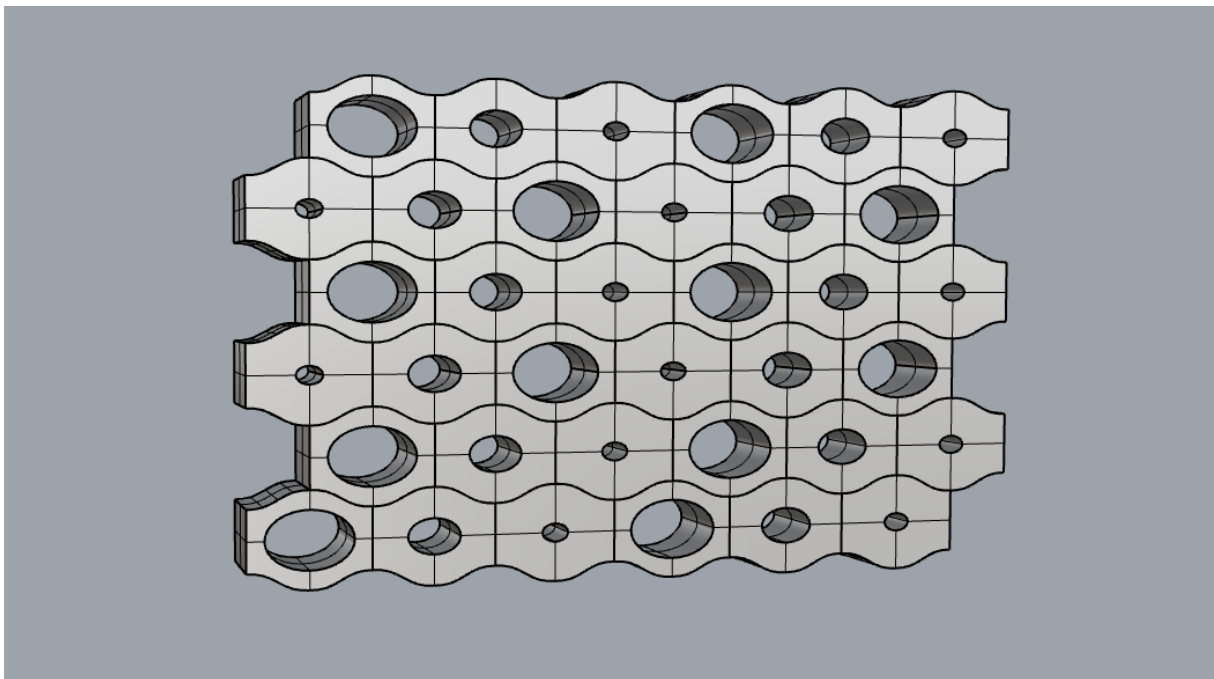

FIGURE 4. The curvy module was designed for a stackable interlocking module system that has ornamental potential when repeated as wall construction.

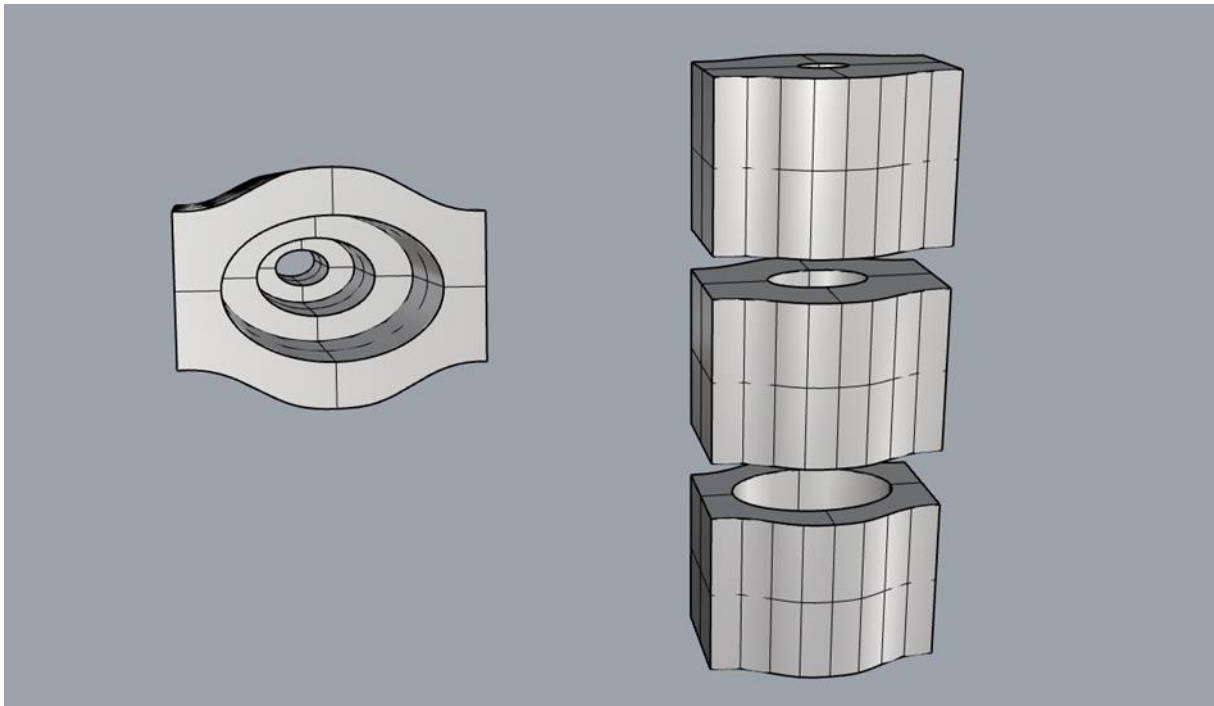

FIGURE 5. Three versions of curvy modules with different wall thicknesses were developed, making it possible to vary a perforated wall in terms of the depth of the surface and thus explore thermal aspects.

THE DEVELOPMENT OF THE FINAL MODULE

Though the curvy modules enabled the consideration, clarification and mutual understanding of the principles related to the thermal aspects and aesthetics, the solution felt clumsy because of the high amount of material required.

Nevertheless, the idea of varying the hollow part of the module to explore thermal aspects inspired us. We wondered how it would be possible to vary the hollow part in one solely extruded module by utilising the plasticity of clay. Our idea was to explore how a combination of standard extrusion techniques could be combined with hands-on manipulation. Extruded elements combined with hands-on manipulation are a well-known craft-based approach, in which the personal touch of the craftsman turns the elements into unique arts and crafts pieces. For example, the Stockholm-based Swedish-Chilean artist Anton Alvarez's practice focuses on designing systems and creating tools and processes for extruding sculptural objects (Alvarez, n.d.).

For the extrusion of our module, we chose to explore a hexagon, since it allows stacking that includes an interlocking system and flexibility in the stacking, given that the module has six sides. This means that the module could be stacked in six ways. Thus, the hexagon provides a high degree of functionality and aesthetic potential.

Initially, the shape of the hexagon was explored, varying the hollow part in simple ways by closing one end with either the bare hands or two wooden sticks as tools (see Figure 6). At this stage, the wall of the extruded module was rather thick (2 cm) and still felt clumsy, which resulted in the development of a 1-cm-thick module to make the expression more delicate.

One experiment based on closing one end by twisting the end of the module caught our attention. From an aesthetic point of view, the twisted part generated a dynamic expression contrasting the straight part of the extruded module. From a functional point of view, the twisted part could strengthen airflow through the module. From there, we investigated different module lengths, varied the length of the twisted area according to the entire module length and, finally, varied the degree of twist. We employed a down-drafted extruder and a pottery wheel and created a box to manage and keep extruded items straight (Figure 7).

The experimental and exploratory approaches reflected the distinctive creative process based on experiential knowledge. The craftsman worked intuitively and in dialogue with materials and techniques, allowing for spontaneous actions and improvisation. A selection of representative examples from the experimental and exploratory investigations of the building module is shown in Figure 8. The production time for one module was about 30 seconds. It was the final setup that took time to develop.

Our final design solution resulted in a hexagonal extruded module of 30 × 10 × 10 cm (see Figure 9). One-third of the module was twisted 180 degrees. The proportion between the twisted and straight parts was determined based on the idea that the straight part enables the module to be stackable while maintaining the twisted part as long as possible to keep a sizeable twisted surface for investigating and strengthening airflow (see Figure 10). The chosen module was also glazed to investigate and utilise colour and glossiness as part of the study.



FIGURE 6. Initial investigation into the extruded hexagon module with a wall thickness of 2 cm and closed with two wooden sticks.



FIGURE 7. Investigation of different lengths of the twisted area according to the entire module length and degree of twist. A down-drafted extruder and a pottery wheel were employed, and a box was created to manage and keep the extruded item straight.



FIGURE 8. Representative examples from the experimental and exploratory investigation into the building modules reflecting the different lengths, lengths of the twisted area according to the entire module length and degree of twist.



FIGURE 9. The final design solution resulted in a hexagonal extruded module of $30 \times 10 \times 10$ cm. One-third of the module is twisted 180 degrees.



FIGURE 10. The proportion between the twisted part and the straight part was determined based on the idea that the straight part enables the module to be stackable and to maintain the twisted part as long as possible.

COMPUTATION-BASED STUDIES OF THE FINAL MODULE

The development of the final module was an exploration of form and techniques concerning stackability and aesthetics. The investigation of the thermal effect and functionality only influenced the final module's development on a conceptual level.

Based on the final developed module, we investigated virtual parametric design-simulation methods conducted via the parameterisation of form and colour coupled with thermal simulations concerning the actual physically produced module.

Nevertheless, the computation-based study and its results are only briefly presented, since this paper focuses on the process in a multidisciplinary approach and how craft practitioners facilitate the aspects of experimentation.

The parallel study aimed to investigate the similarities between physical and virtual modules, specifically the thermal aspects, and to clarify how the computation-based tool enabled us to scale up and virtually work with a more reliable degree of complexity.

Thermography, a thermometer and an infrared anemometer were used to conduct the thermal measurements. The thermography used a Flir One Pro thermal camera with Vernier Thermal Analysis software to record and log data. Thermography registrations were used to capture and analyse the surface temperature of the clay module parts that were glazed in colour (see Figure 11).

Air velocity movement through the cavity of the clay modules was investigated using two Testo infrared anemometers, model 405i. One anemometer was placed inside the module and centred in the cross section. The second anemometer was placed outside the module (see Figure 12).

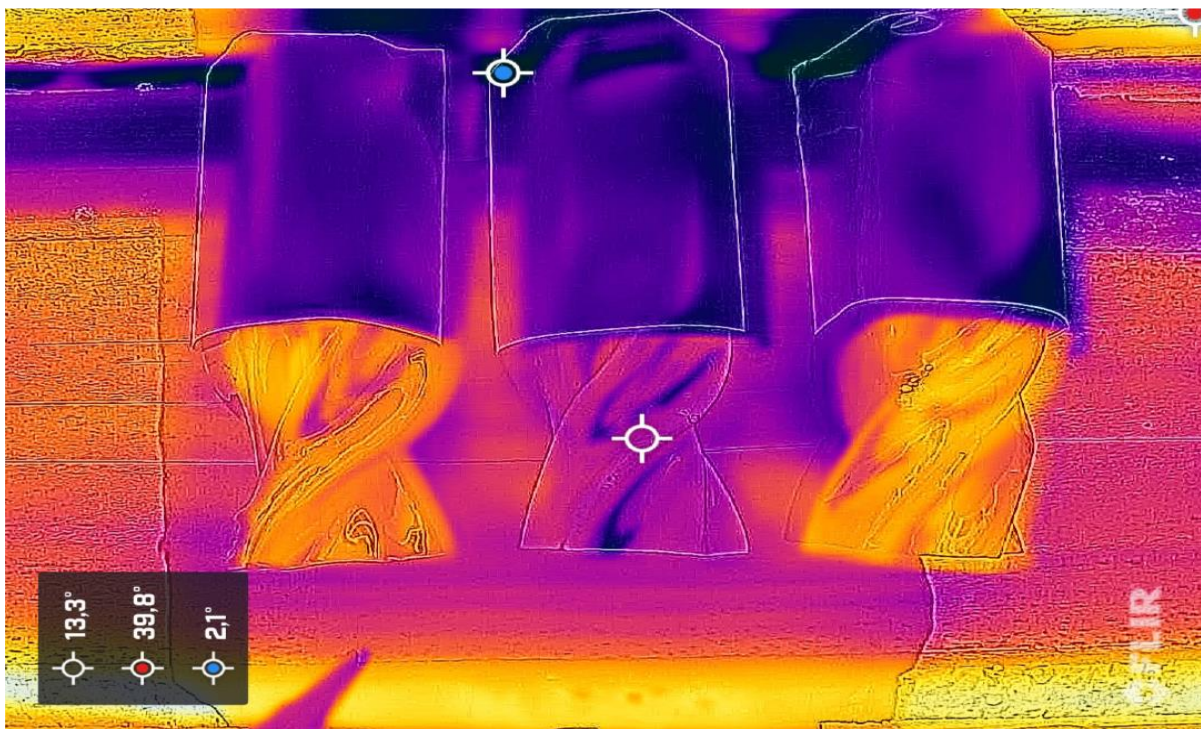

FIGURE 11. Thermography registrations of glazed surfaces by solar radiation exposure from 9:00–10:30, 12 May 2023, Copenhagen. Green glazing to the left, white in the centre and dark brown to the right.



FIGURE 12. Airflow registrations of a single tile with an anemometer placed inside/outside the module.

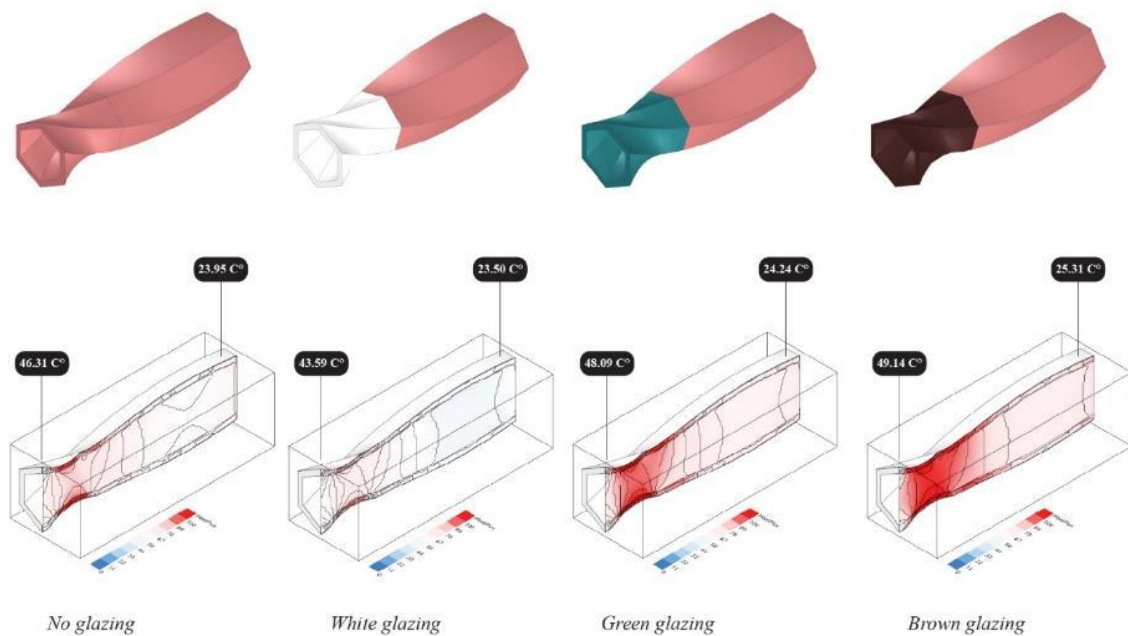

FIGURE 13. Thermography computational studies focused on the form and colour of different versions, coupled with dedicated thermal simulations for singular modules.

The computational studies focused on form and colour, coupled with dedicated thermal simulations for the modules. The thermal simulations proceeded as follows: a) temperature increase in the air inlet and outlet area of modules with colour variations was simulated, b) thermal flux of the bespoke module was

simulated to investigate and understand the heat movement through the module and c) the resulting outlet air temperature of the module was mapped (see Figure 13).

The results of the measurements of the physical model versus the computation-based studies conducted by parameterisation of form and colour, coupled with the thermal simulations, showed similarities. Therefore, the two modes of investigation can be considered complementary, as they cover both qualitative and quantitative material-formal-thermal results.

REFLECTION AND CONCLUSION

This research investigated the direct relationship between qualitative craft methods and quantitative computational design methods. The aim was to discuss the developed method and process in a multidisciplinary approach that combined the quality of craft-based practice with the skills found in architecture, engineering and programming. The study's most important contribution is the development of thermal building modules, as it aimed to explore and discuss the potential of a multidisciplinary approach.

The craft-based approach in this study is characterised by a creative process based on experiential knowledge, in which the craftsperson works intuitively to enable spontaneous actions and improvisation. In contrast, the computational design method was based on mathematical modelling and structured numerical versioning as investigation methods. The study asked how a craftsperson highlight the importance of experimentation with material, technique and aesthetics during multidisciplinary collaboration.

We found that immediate concrete design proposals demonstrated a helpful way of establishing common ground for multidisciplinary collaboration. The concrete design proposals worked as pivotal points for addressing the advantages and disadvantages of the suggested design and clarified the differences and potentials between the specialisations in question. Based on the immediate design proposals, it was clear how the craftsperson's previous experiences quickly resulted in the identification of potentials regarding experimental setups and aesthetic solutions based on the material and techniques in question, while simultaneously providing foresight into possible complications. For example, as part of the study, we questioned how we could vary the hollow part in an extruded module by utilising the plasticity of clay. The question initiated a systematic exploration of form based on clay extrusion and hands-on manipulation that considered the aesthetics and functionality of the building module. The experimental and exploratory approach reflected the craftsperson's intuitive way of working in dialogue with materials and techniques, allowing spontaneous actions and improvisation where the final solution was difficult to predict. Thus, through practice, the research approach developed knowledge from an insider perspective and explored ways to learn from practice. While the developed modules were unique in their specific formal definition, they were based on a precise and distinct execution grounded in material control, extrusion speed, rotation speed, cutting process, drying and firing.

Extensive experimentation with clay extrusion and hands-on manipulation resulted in an excellent variety of design solutions. Nevertheless, we chose only to study one module when it came to computer-based thermal measurements. Future research needs to investigate the differences between design solutions and thermal and aesthetic potentials. Furthermore, it would be interesting to investigate how industry fabrication processes can combine craft-based techniques and sophisticated computational design methods in automated fabrication processes to support richness in making and production.

REFERENCES

- Alvarez, A. (n.d.). *Anton Alvarez*. <http://antonalvarez.com/>
- Binder, T., & Redström, J. (2006). Exemplary design research. *DRS Biennial Conference Series*. <https://dl.designresearchsociety.org/drs-conference-papers/drs2006/researchpapers/51>
- Brinck, I., & Reddy, V. (2020). Dialogue in the making: Emotional engagement with materials. *Phenomenology and the Cognitive Sciences*, 19(1), 23–45. <https://doi.org/10.1007/s11097-019-09629-2>
- Bundgaard, R. (2021). *DIVERSITY by Strøjer Tegl – Klink, R.* <http://cargocollective.com/klink/Product-DIVERSITY-by-Strojer-Tegl>
- Dormer, P. (1994). *The art of the maker*. Thames and Hudson.
- Hawkes, D. (2019). *The environmental imagination: Technics and poetics of the architectural environment* (2nd ed.). Taylor & Francis. <https://doi.org/10.4324/9781315210575>
- IPCC. (2021). *Climate change 2021: The physical science basis, United Nations*. Cambridge University Press. <https://doi:10.1017/9781009157896>.
- Johns, R. L., Kilian, A., & Foley, N. (2014). Design approaches through augmented materiality and embodied computation. In W. McGee & M. Ponce De Leon (Eds.), *Robotic fabrication in architecture, art and design 2014* (pp. 319–332). Springer International Publishing. https://doi.org/10.1007/978-3-319-04663-1_22
- Joshi, D. K. (2018). Passive cooling techniques in ancient Indian buildings: A study. *International Journal of Architectural Heritage*, 1(2), 11–20. <https://doi.org/10.37628/v1i2.421>
- Leach, B. (1976). *A potters book*. Faber & Faber.
- Moe, K. (2013). *Convergence: An architectural agenda for energy*. Routledge & CRC Press. <https://www.routledge.com/Convergence-An-Architectural-Agenda-for-Energy/Moe/p/book/9780415824910>
- Sennett, R. (2008). *The craftsman*. Yale University Press.